

Beograd - 011/322 15 00, e-mail: officebg@mn.co.rs, Ugrinovci - 064/ 803 55 18, 063/ 803 55 19
e-mail: mn.ugrinovci@mn.co.rs, Novi Sad - 021/472 65 40, e-mail: officens@mn.co.rs,
Loznica - 015/879-802, Fax: 015/879-888, e-mail:office@mn.co.rs, www.mn.co.rs



**BEOGRAD
NOVI SAD
LOZNICA**

FABRIKA BETONSKE GALANTERIJE LOZNICA

PROIZVODNI PROGRAM



BEOGRAD

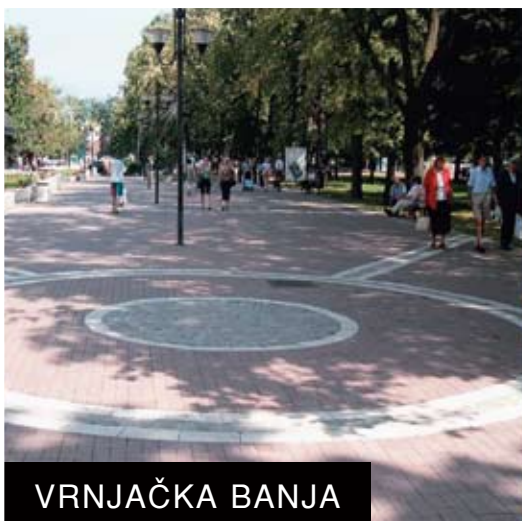

VRNJAČKA BANJA



LOZNICA



PEĆINCI



BEOGRAD



OBRENOVAC



BANJA KOVILJAČA



NOVI SAD



GUČEVO



Najveća srpska fabrika betonske galanterije "MN" Loznica, podignuta na Drini na obodu Loznice 2001. godine, za vrlo kratko vreme se afirmisala u najboljem svetlu.

Iako je repertoar betonske galanterije, vibropresovanih betonskih ploča stigao u našu zemlju sa zakašnjenjem, bilo je poznato da se radi o novom građevinskom materijalu kojim je oblikovana urbana parterna arhitektura od najmanjih do najvećih gradova sveta.

Fabrika betonske galanterije "MN" Loznica je za vrlo kratko vreme proizvela i ugradila svoje proizvode po mnogim gradovima Srbije, postavljajući rekord na rekonstrukciji poteza Slavija-Terazije u Beogradu, kada je za samo dva meseca ugrađeno 15000 kvadratnih metara betonskih ploča na kompletnim obostranim trotoarima i priključnim uličnim raskršćima.

Sa pločama "MN" Loznica centralni potez starog gradskog jezgra: Slavija-"London"-Terazije dobio je potpuno nov i svečan izgled, doličan gradu iz porodice velikih evropskih metropola.

Posle prvih početnih uspeha a i zbog velike potražnje naših proizvoda usledila je izgradnja potpuno nove fabrike, novih proizvodnih pogona sa najsavremenijom opremom renomirane nemačke firme "MASA".

Krajem 2007. god. puštena je u pogon naša fabrika. Fabrika je najveća ove vrste u regionu. Sa novom fabrikom udvostručen je asortiman proizvoda.

Pred vama je katalog naših proizvoda, sa našim realizacijama različitih urbanih celina u više gradova Srbije.

Sa našom vibro presovanom betonskom galanterijom uredićete brzo, i to po najpovoljnijim cenama:

gradske ansamble:

- trotoare -
- kolovoze -
- skverove -
- trgove -
- parkove -
- sportske terene -
- parkinge -

male kućne urbane prostore:

- vrtove
- dvorišta
- dečija igrališta
- žardinjere
- kaskade
- garaže
- ograde





NOVA
NAJVEĆA

FABRIKA

BETONSKE
GALANTERIJE
U REGIONU





BEOGRAD - PRAVNI FAKULTET



BEOGRAD - TEHNIČKI FAKULTET



ŠABAC

Kao najveći proizvođač vibro-presovanih betonskih elemenata u Republici Srbiji, sa sedmogodišnjim iskustvom, ispunili smo stroge zakonske propise u pogledu kvaliteta proizvoda i zaštite životne sredine. U predhodnoj 2007. godini napravili smo veliki korak u proširenju asortimana proizvoda i korišćenju novih materijala za završne slojeve proizvoda uvozom raznolikih agregata (kvarca, granita) raznih boja i granulometrijskog sastava. Sve to je omogućeno izgradnjom nove, velike, potpuno automatizovane, kompjuterski vođene fabrike za proizvodnju betonskih vibro-presovanih proizvoda. U sastavu fabrike nalazi se moderna, potpuno automatizovana fabrika betona. Posedujemo liniju za specijalnu obradu gotovih betonskih proizvoda tzv. obrada ploča pranjem, gde se kao finalni rezultat dobija izuzetno lep vizuelni efekat. Kao inovaciju uvodimo tzv. color-mix tehnologiju koja omogućava izradu završnih slojeva u najraznovrsnijim kombinacijama tri ili četiri boje po željama kupaca.

Dnevni kapacitet fabrike je 2000m² betonskih vibro-presovanih ploča.

Svi naši proizvodi zadovoljavaju standarde definisane važećom zakonskom regulativom. Za sve proizvode posedujemo ateste o kvalitetu istih. U cilju svakodnevne kontrole kvaliteta proizvoda i materijala vršimo potrebna ispitivanja u sopstvenoj laboratoriji koja je opremljena svom potrebnom, atestiranom opremom za ispunjavanje kvaliteta proizvoda, odnosno ispunjavanje standarda: EN 1338, EN 1339 i EN 1340.

Pri proizvodnji vibro-presovanih betonskih elemenata koristimo aditive i boje nemačke proizvodnje.

Naša građevinska operativa izvodi radove širom Republike Srbije. Opremljeni smo svom potrebnom mehanizacijom za izvođenje celokupnih radova: od iskopa, dopreme gotovih proizvoda iz fabričkog skladišta do gradilišta, do finalne obrade ugrađenih vibro-presovanih elemenata.

Osim naših proizvoda i ugradnje istih nudimo Vam mogućnost izrade idejnih rešenja za ispunjenje Vaših želja.

**Posetite nas, budite naši komitenti.
Sigurni smo da ćete biti zadovoljni.**

ASORTIMAN
PLOČA:

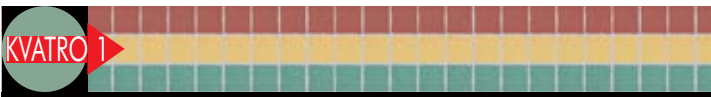

BEOGRAD I ŠIROM SRBIJE: NOVI SAD, LAJ

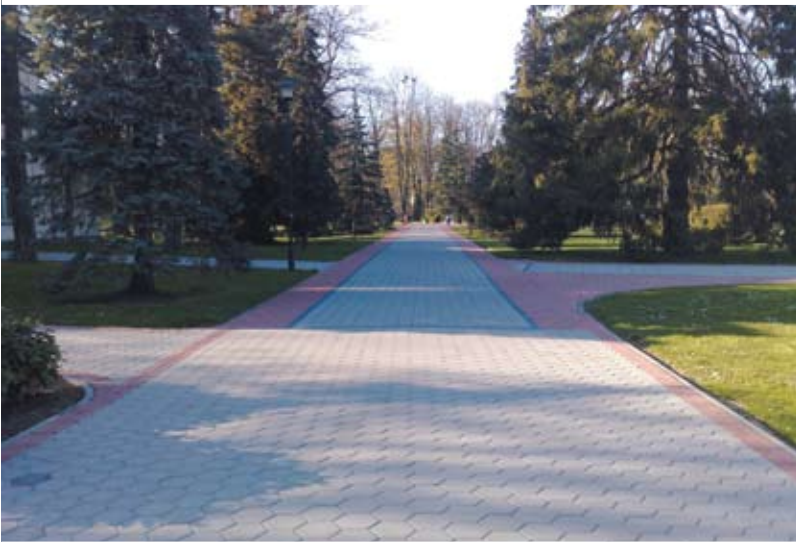

KOVAC, LOZNICA, OBRENOVAC, UB, ŠABAC

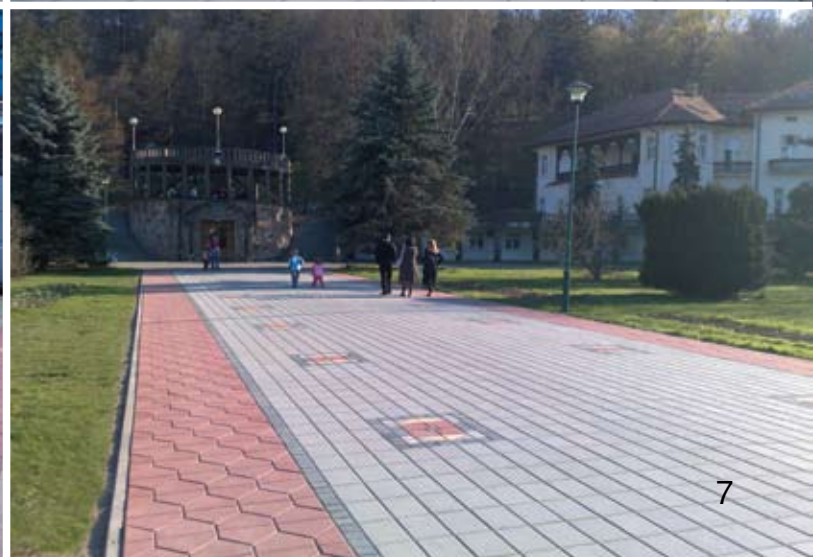

BANJA KOVILJAČA, VRNJAČKA BANJA, ZRENJANIN

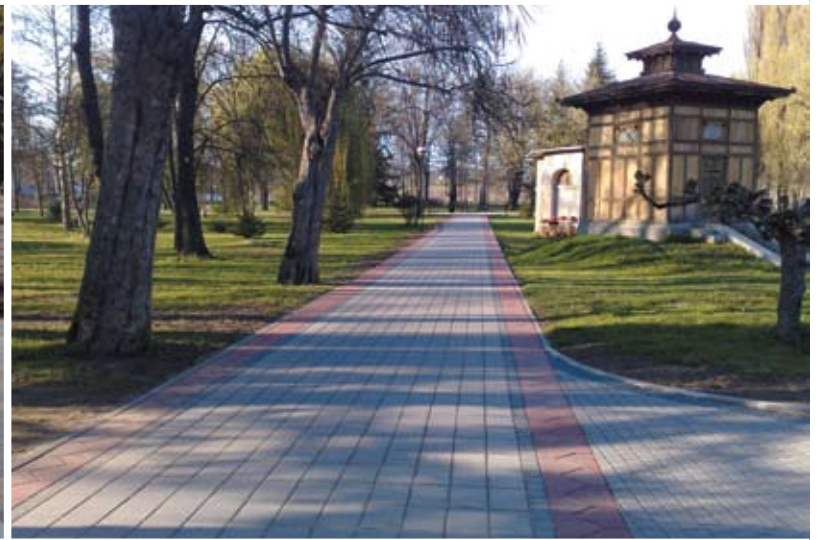

SEKSTA

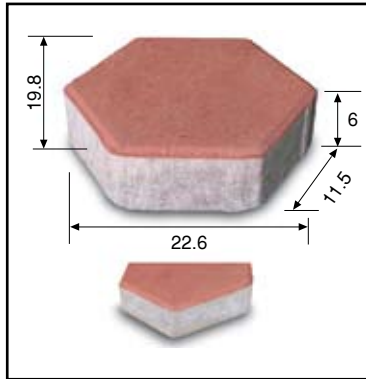

PROIZVODI SE

U BOJAMA

ZAVRŠNA OBRADA

- GLATKA

- PRANA

- COLOR MIX



BETONA

BRAON

CRVENA

ZELENA

CRNA

TERAKOTA



SEKSTA



Banja Koviljača



GRADSKI PARK - Loznica

KVATRO 1

BETONA
BRAON
CRVENA
ZELENA
CRNA
TERAKOTA



PROIZVODI SE

U BOJAMA

ZAVRŠNA OBRADA
- GLATKA
- PRANA
- COLOR MIX

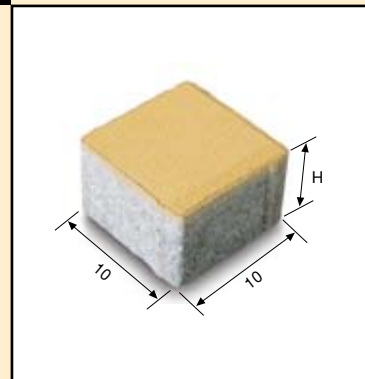

10 x 10 x H
H=6cm, H=8cm



Banja Koviljača



Beograd



MADERA - Beograd



Banja Koviljača

KVATRO 12

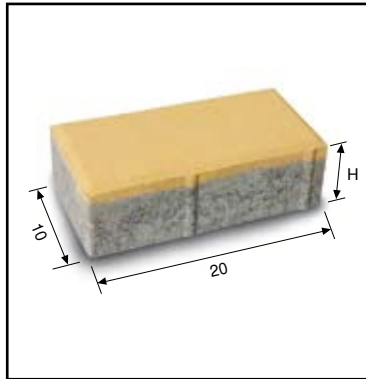

10 x 20 x H
H=6cm, H=8cm

PROIZVODI SE

U BOJAMA

ZAVRŠNA OBRADA
- GLATKA
- PRANA
- COLOR MIX



BETONA
BRAON
CRVENA
ZELENA
CRNA
TERAKOTA



Šabac



Banja Koviljača

KVATRO 2

BETONA
BRAON
CRVENA
ZELENA
CRNA
TERAKOTA



PROIZVODI SE

U BOJAMA

ZAVRŠNA OBRADA
- GLATKA
- PRANA
- COLOR MIX

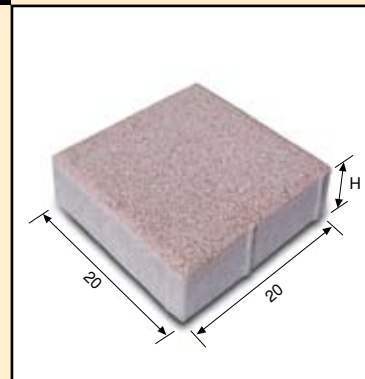

20 x 20 x H
H=6cm, H=8cm



Pećinci



Šabac

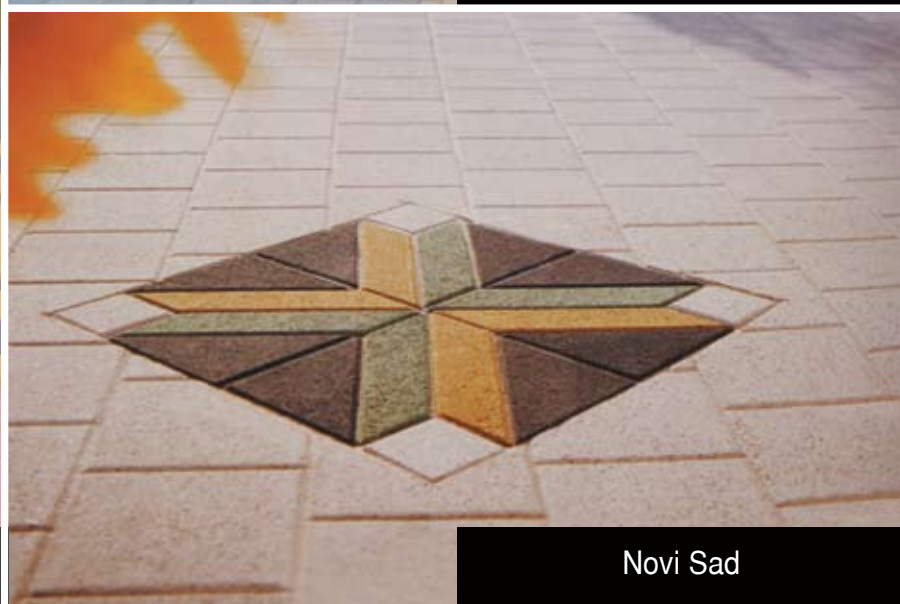

Novi Sad

KVATRO 3

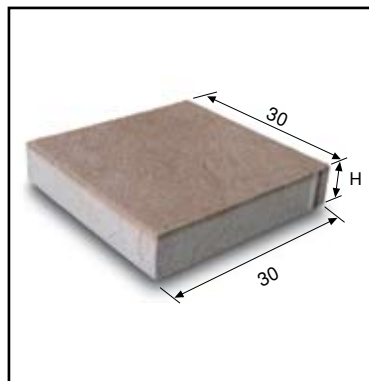

30 x 30 x H

H=5cm, H=6cm, H=8cm

PROIZVODI SE

U BOJAMA

ZAVRŠNA OBRADA
- GLATKA
- PRANA
- COLOR MIX



BETONA
BRAON
CRVENA
ZELENA
CRNA
TERAKOTA



STARI DVOR - Beograd



Beograd

KVATRO 32

KVATRO 32

BETONA
BRAON
CRVENA
ZELENA
CRNA
TERAKOTA



PROIZVODI SE

U BOJAMA

ZAVRŠNA OBRADA

- GLATKA

- PRANA

- COLOR MIX

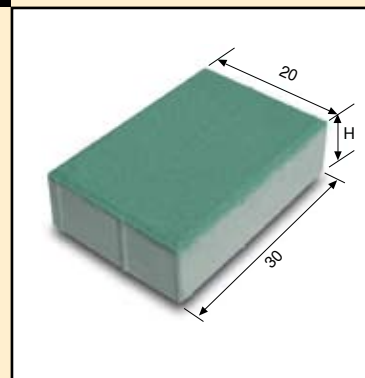

30 x 20 x H
H=6cm, H=8cm

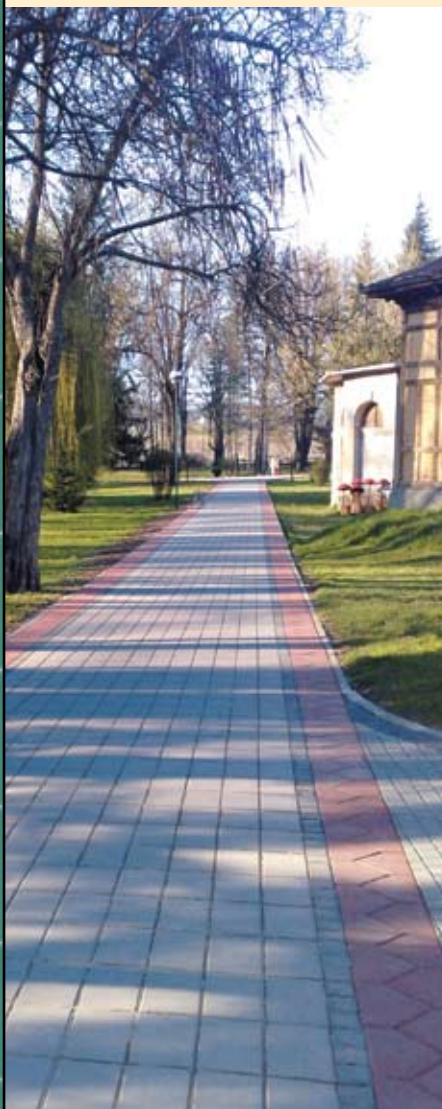

Banja Koviljača



Beograd



Banja Koviljača

KVATRO 4

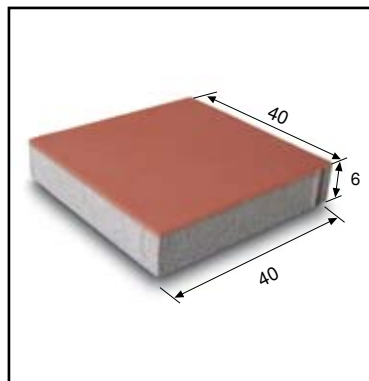

40 x 40 x 6cm

PROIZVODI SE

U BOJAMA

ZAVRŠNA OBRADA
- GLATKA
- PRANA
- COLOR MIX



BETONA
BRAON
CRVENA
ZELENA
CRNA
TERAKOTA



KVATRO 4



KVATRO 5

KVATRO 5

BETONA
BRAON
CRVENA
ZELENA
CRNA
TERAKOTA



PROIZVODI SE

U BOJAMA

ZAVRŠNA OBRADA

- GLATKA

- PRANA

- COLOR MIX

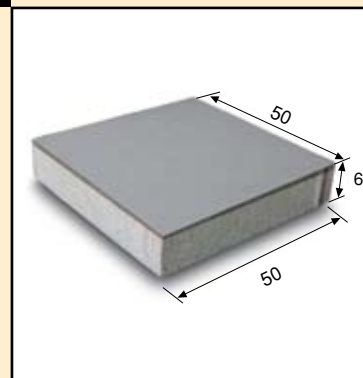

50 x 50 x 6cm

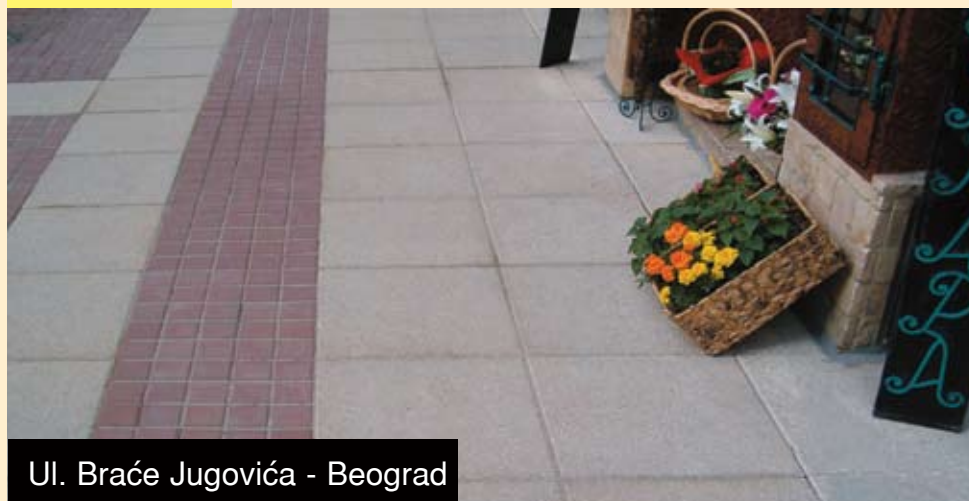

Ul. Braće Jugovića - Beograd



Novi Sad

ROMANIKA

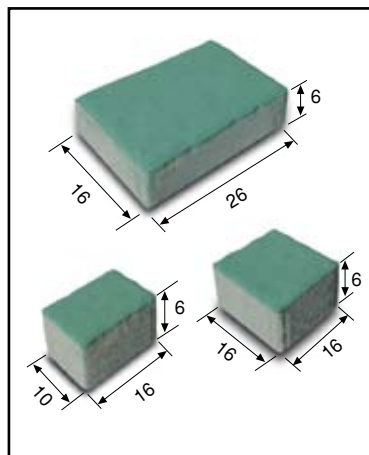

PROIZVODI SE

U BOJAMA

ZAVRŠNA OBRADA

- GLATKA

- PRANA

- COLOR MIX



BETONA

BRAON

CRVENA

ZELENA

CRNA

TERAKOTA



ROMANIKA



EX-L

EX-L

BETONA
BRAON
CRVENA
ZELENA
CRNA
TERAKOTA



PROIZVODI SE

U BOJAMA

ZAVRŠNA OBRADA
- GLATKA
- PRANA
- COLOR MIX

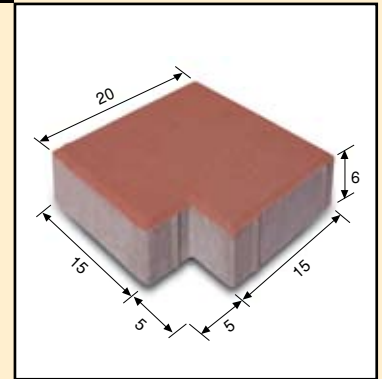

20 x 20 x 6cm



Pećinci

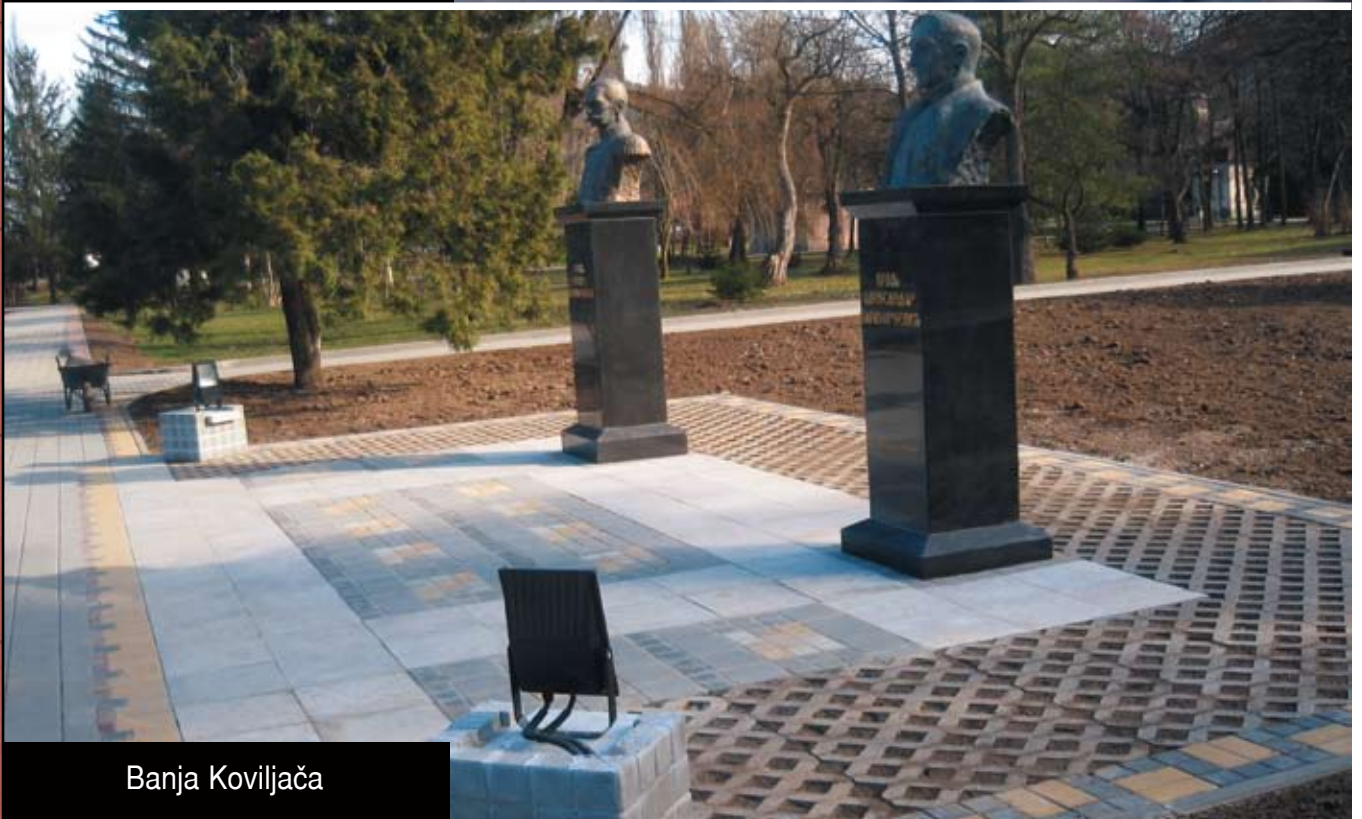

Banja Koviljača

KOBRA

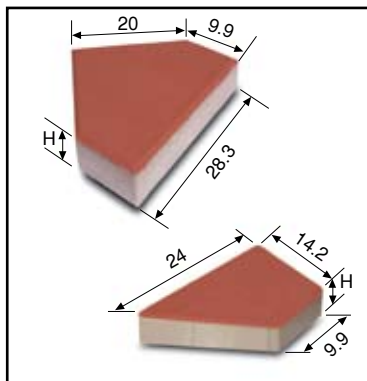

H=6cm, H=8cm

PROIZVODI SE

U BOJAMA

ZAVRŠNA OBRADA
- GLATKA
- PRANA
- COLOR MIX



BETONA
BRAON
CRVENA
ZELENA
CRNA
TERAKOTA



KOBRA



Banja Koviljača



ROMB

ROMB

BETONA
BRAON
CRVENA
ZELENA
CRNA
TERAKOTA



PROIZVODI SE

U BOJAMA

ZAVRŠNA OBRADA

- GLATKA

- PRANA

- COLOR MIX

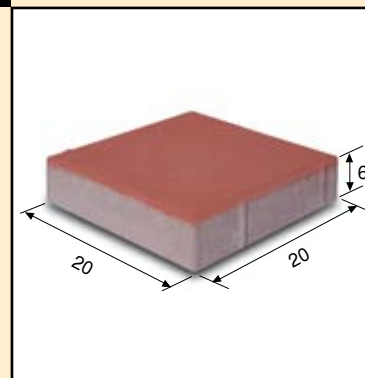

20 x 20 x 6cm



SAĆE

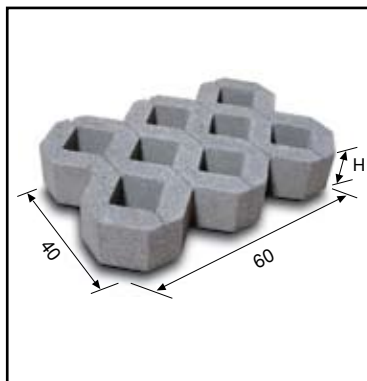

60 x 40 x H
H=8cm, H=10cm

PROIZVODI SE
U BOJAMA



BETONA
BRAON
CRVENA
ZELENA
CRNA
TERAKOTA



„AUTOKOMERC” - Beograd

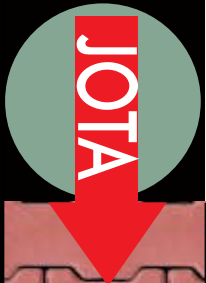

JOTA

BETONA
BRAON
CRVENA
ZELENA
CRNA
TERAKOTA



PROIZVODI SE

U BOJAMA

ZAVRŠNA OBRADA
- GLATKA
- PRANA
- COLOR MIX

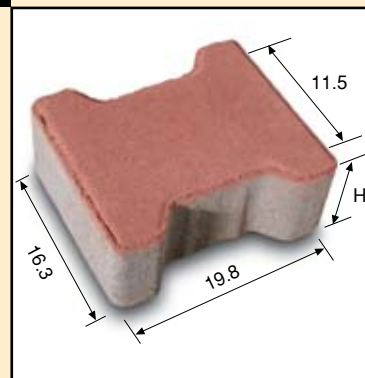

19.8 x 16.3 x H
H=6cm, H=8cm



REBRO

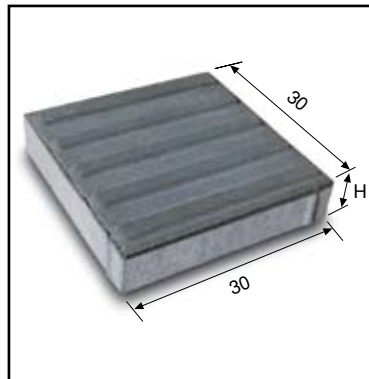

30 x 30 x H
H=6cm, H=8cm

PROIZVODI SE
U BOJAMA



BETONA
BRAON
CRVENA
ZELENA
CRNA
TERAKOTA



ul. Kralja Milana - Beograd

TOKA

TOKA

BETONA
BRAON
CRVENA
ZELENA
CRNA
TERAKOTA



**PROIZVODI SE
U BOJAMA**

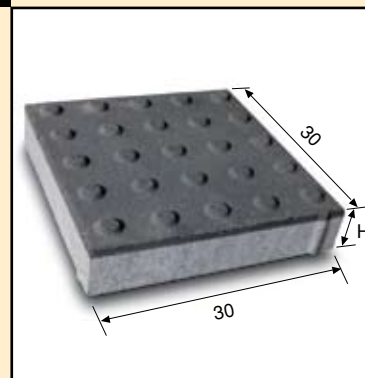

**30 x 30 x H
H=6cm, H=8cm**



ŽARDINJERE



Pecinci

KLUPA TIP 3M

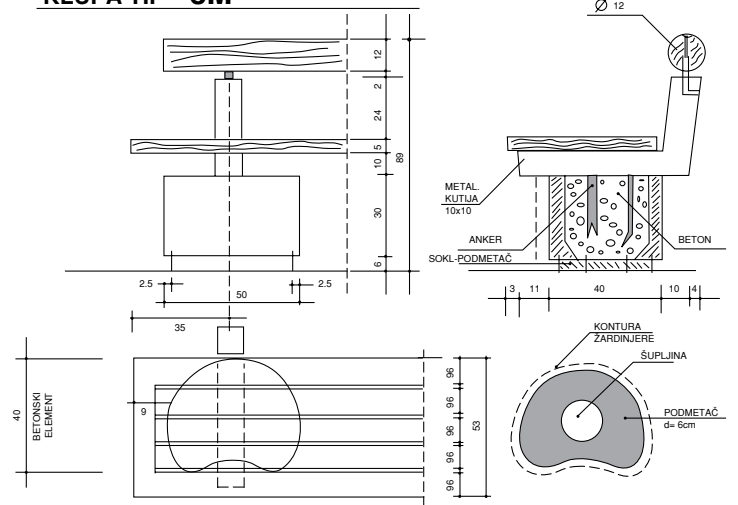

KALDRMA

BETONA
BRAON
CRVENA
ZELENA
CRNA
TERAKOTA



PROIZVODI SE
U BOJAMA

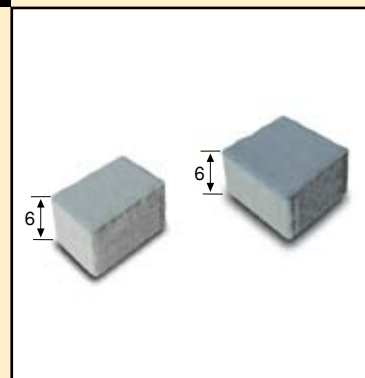

H=6cm



Trg Vuka Karadžića Loznica





Ivana Milutinovića



Katićeva



Tršova

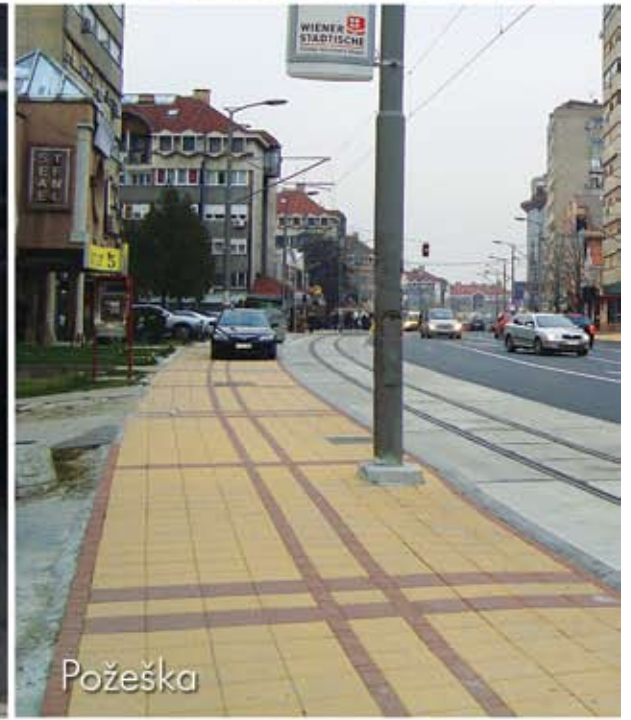

Požeška



28
Beligradska



Birčaninova



Resavska



Trg Republike



Klub Književnika



Resavska



Savograd



Savograd

IVIČNJACI

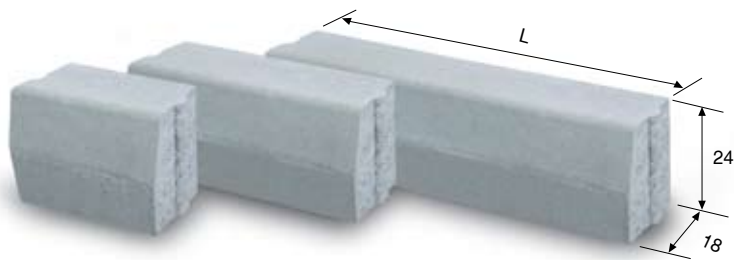

24 x 18 x L, L=100, 50, 25

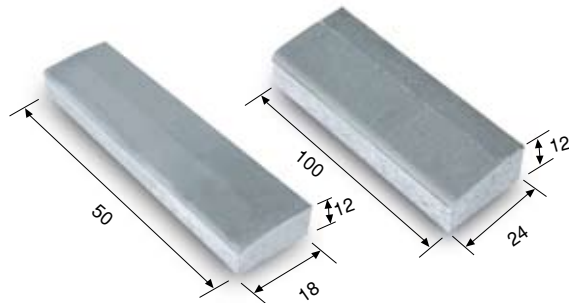

12 x 18 x 50, 12 x 24 x 100

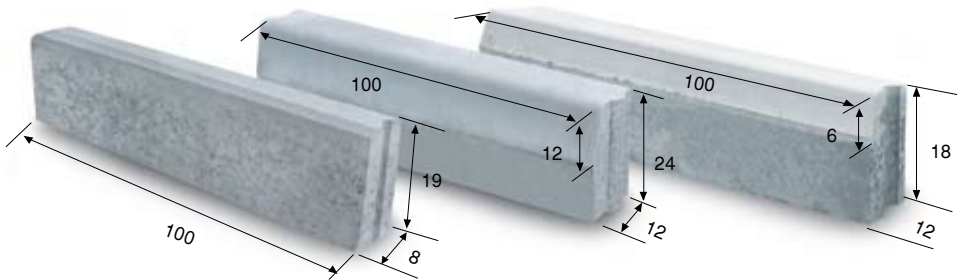

19 x 8 x 100

24 x 12 x 100

18 x 12 x 100

KANALETE

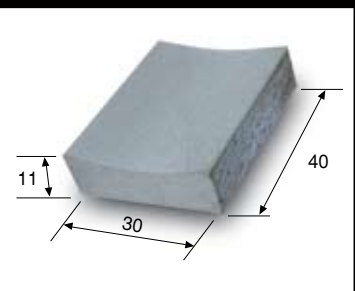

BET. BLOK

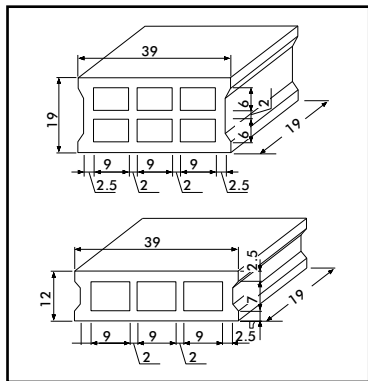

URADI SAM

POZOVI TEL: 015/879-800

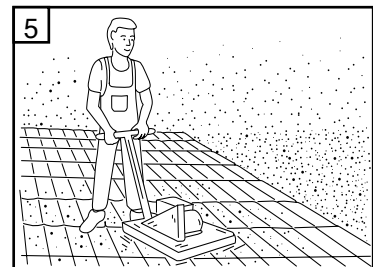
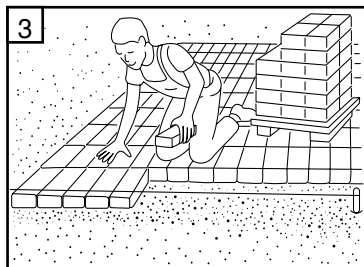
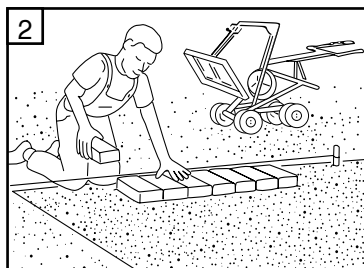
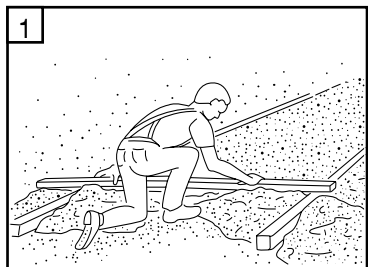
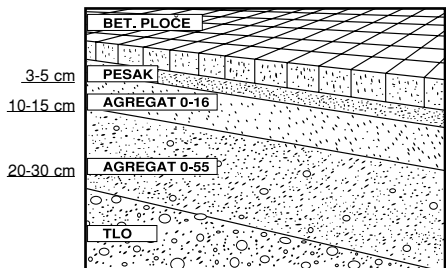

PROIZVODIMO



PROJEKTUJEMO

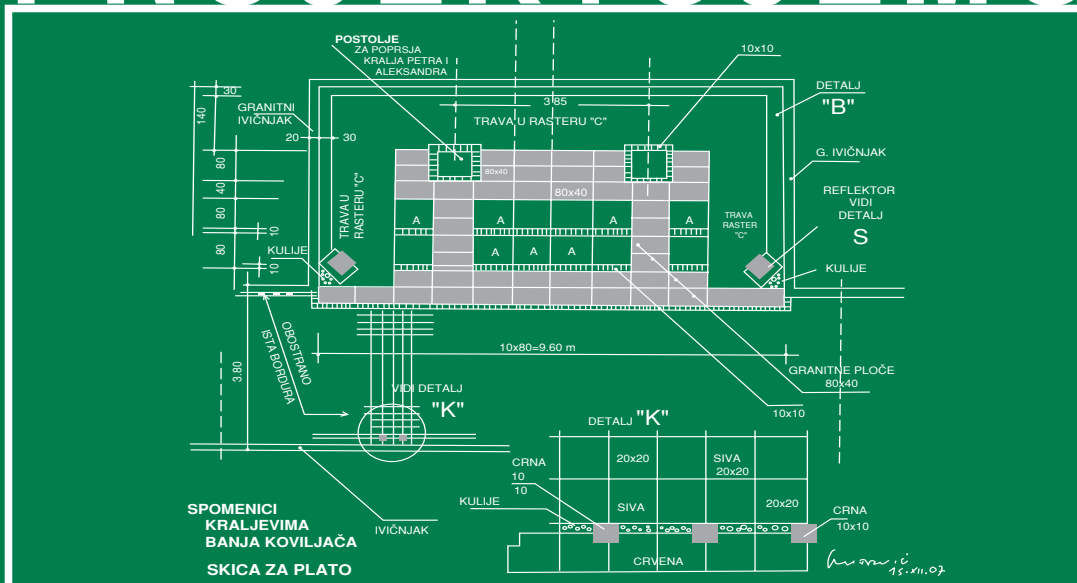

GRADIMO



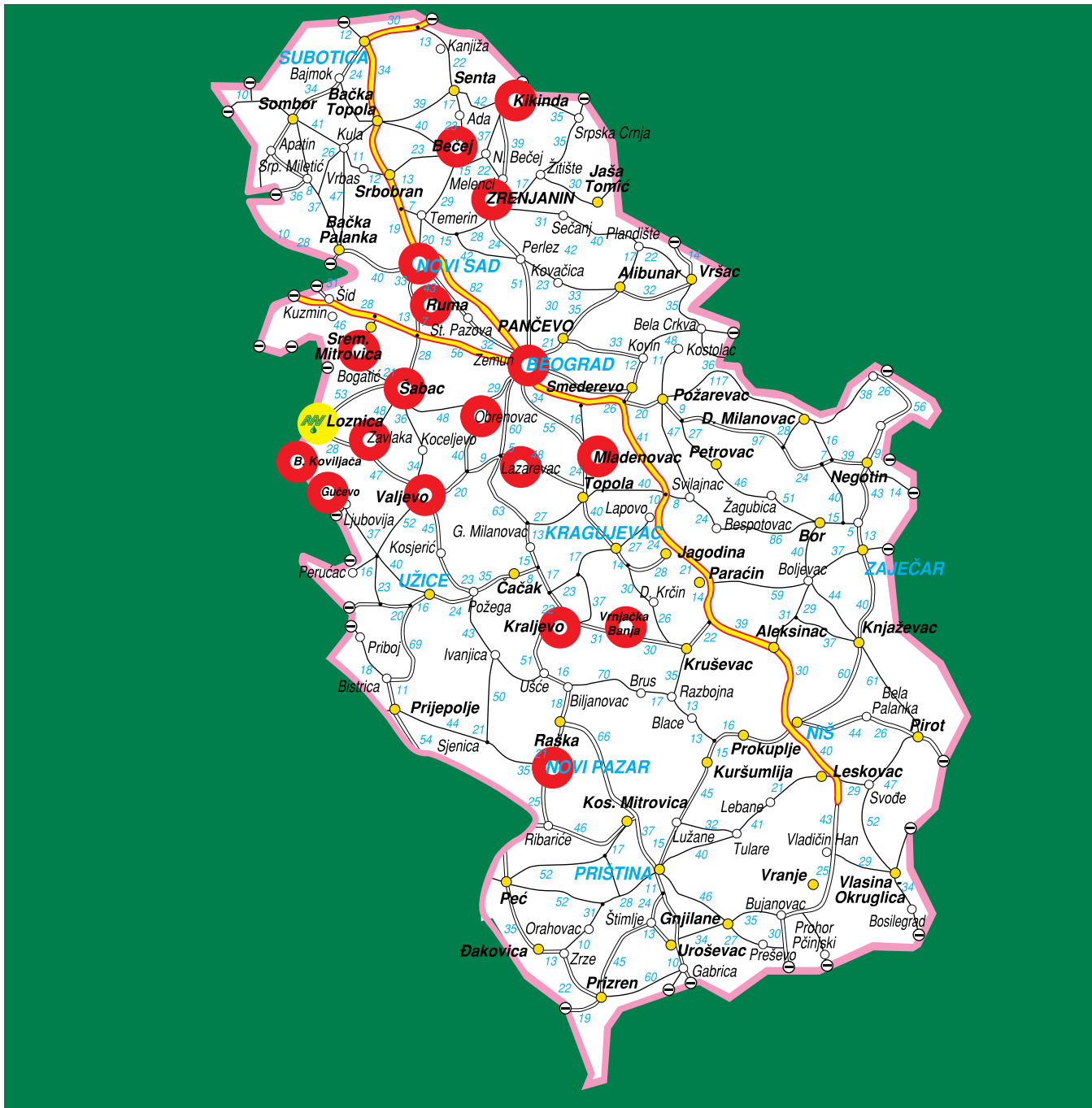

“MN” d.o.o.

Beograd - 011/322 15 00, e-mail: officebg@mn.co.rs, Ugrinovci - 064/ 803 55 18, 063/ 803 55 19
 e-mail: mn.ugrinovci@mn.co.rs, Novi Sad - 021/472 65 40, e-mail: officens@mn.co.rs,
 Loznica - 015/879-802, Fax: 015/879-888, e-mail:office@mn.co.rs
 www.mn.co.rs